

# DIAPHRAGM PUMPS

12



## SLL series

SLL-20 / SLL-30 / SLL-40 / SLL-50

### Product characteristics

- Integrated overload protection
- Connecting hose included in delivery

### Dimensions

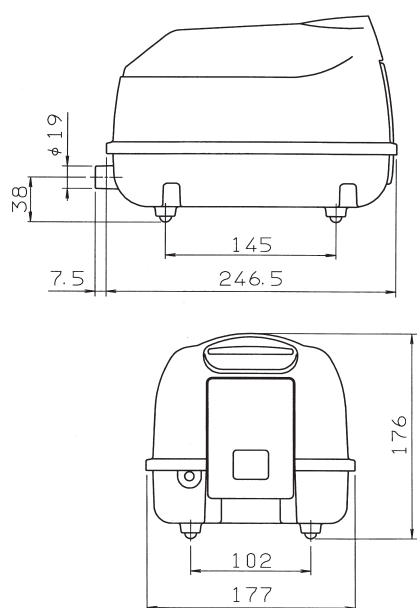

### Technical data

Model			SLL-20	SLL-30	SLL-40	SLL-50
Air flow <sup>1)</sup>	l/min	0 mbar	52	60	68	75
		50 mbar	44	52	60	68
		100 mbar	36	43	53	61
		150 mbar	28	34	45	53
		200 mbar	18	26	36	44
Voltage <sup>2)</sup>	VAC		230	230	230	230
Power consumption	W	180 mbar	18	27	41	53
Noise level	dB(A)		30	32	33	37
Dimensions	mm	L x W x H	254 x 177 x 176			
Connection	mm	Ø outside	19	19	19	19
Net weight	kg		4.5	4.5	4.5	4.5

<sup>1)</sup> Product performance may vary +/- 10% from performance curves

<sup>2)</sup> Values at 50 Hz

### Performance data

