



















# Series variation

Valve type	Air operated valve												
	2-port												
Exterior appearance/ Recorded page	AMDZ*3R  ...Page 2	AMD3/4/5*3R  ...Page 4	AMDZ/0  ...Page 18	AMD0*2  ...Page 22	AMD3*2  PFA body type .....Page 26	AMD4*2  PFA body type .....Page 36	AMD5*2  PFA body type .....Page 44	AMD*1H  ...Page 52	AMD*1M  ...Page 56	Stainless steel body type .....Page 32	Stainless steel body type .....Page 40	Stainless steel body type .....Page 48	
	Body material	PFA/PTFE body	PFA/PTFE body	PFA/PTFE body	PFA/PTFE body	PFA/PTFE body	Stainless steel body	PFA/PTFE body	Stainless steel body	PFA/PTFE body	Stainless steel body	PFA body	PFA body
Orifice size or drip prevention amount	φ3.5/φ4	φ6 to φ20	φ1.6 to φ4	φ3 to φ4	φ6.3 to φ10	φ8/φ10	φ14.7 to φ16	φ16	φ20	φ20	φ10 to φ25	φ8 to φ22	
Connection (fitting type)	Super-type pillar fitting		●	●	●		●		●				
	Super 300 type pillar fitting	●	●	●	●		●		●		●	●	
	F-LOCK 20 Series fitting			●	●								
	F-LOCK 20A Series fitting			●	●								
	F-LOCK 60 Series fitting	●	●	●	●	●		●	●				
	Final Lock fitting			●	●	●		●	●				
	Flaretek fitting			●	●	●		●			●		
	PFA pipe projection for welding											●	
	PVC union fitting									●			
	Rc thread			●	●		●		●				
SUS tube extension						●		●		●			
Double barbed fitting						●		●		●			
Option	—	With: flow rate adjuster, sensor, bypass	With: flow rate adjuster	With: flow rate adjuster, indicator, For: liquid ammonia, liquid nitric acid	With: flow rate adjuster, indicator, bypass; For: liquid ammonia, liquid nitric acid/fluoresin, high temperature (5 to 160°C)	With: flow rate adjuster, indicator	With: flow rate adjuster, indicator, bypass; For: liquid ammonia, liquid nitric acid/fluoresin, high temperature (5 to 160°C)	With: flow rate adjuster, indicator	With: flow rate adjuster, indicator, bypass; For: liquid ammonia, liquid nitric acid/fluoresin	With: flow rate adjuster, indicator	Ammonia specifications	—	
Applications	Chemical liquid supply equipment; Cleaning equipment		Coater/ Developer	Chemical liquid supply equipment; Cleaning equipment				Chemical liquid supply equipment					

## Sister products

Air operated valve	Manual valve
2-port	2-port
AMD2/3/4/5*...Page 106	MMD .....Page 152
	
Use: Chemical liquid supply equipment cleaning equipment	Use: Chemical liquid supply equipment cleaning equipment

## Peripheral devices

Toggle valve	Flow rate adjusting valve		Regulator	
2-port	Manual type	Electric type	PMP202...Page 180	PYM...Page 184
TMD.....Page 156	FMD00.....Page 162	MNV.....Page 166	PMP402...Page 180	
				
			PMM20...Page 186	PMM50...Page 188
				
Use: Chemical liquid supply equipment cleaning equipment	Use: Chemical liquid supply equipment cleaning equipment	Use: Single wafer cleaning equipment	<ul style="list-style-type: none"> <li>● Connection: Rc1/8, Rc1/4 (φ8, φ10 for PMM20)</li> <li>● Set pressure range: 0.02MPa to 0.2MPa</li> </ul>	
Use: Coater/developer				





# Safety Precautions

Be sure to read this section before use.

When designing and manufacturing equipment using CKD products, the manufacturer is obligated to ensure that the safety of the mechanism, pneumatic control circuit and/or water control circuit and the system that runs the electrical controls are secured.

It is important to select, use, handle and maintain CKD products appropriately to ensure their safe usage.

Observe warnings and precautions to ensure device safety.

Check that device safety is ensured in order to manufacture a safe device.

## WARNING

**1** This product is designed and manufactured as a general industrial machine part. It must be handled by an operator having sufficient knowledge and experience.

**2** Use this product in accordance with specifications.

This product must be used within its stated specifications. In addition, never modify or additionally machine this product. This product is intended for use in general industrial machinery equipment or parts. It is not intended for use outdoors (except for products with outdoor specifications) or for use under the following conditions or environments. (Note that this product can be used when CKD is consulted prior to its usage and the customer consents to CKD product specifications. The customer should provide safety measures to avoid danger in the event of problems.)

- ① Use for applications requiring safety, including nuclear energy, railways, aircraft, marine vessels, vehicles, medical devices, devices or applications in contact with beverages or foodstuffs, amusement devices, emergency cutoff circuits, press machines, brake circuits, or safety devices or applications.
- ② Use for applications where life or assets could be significantly affected, and special safety measures are required.

**3** Observe organization standards and regulations, etc., related to the safety of the device design and control, etc.

ISO4414, JIS B 8370 (General rules for pneumatic systems)

JFPS2008 (Principles for pneumatic cylinder selection and use)

Including the High Pressure Gas Safety Act, Industrial Safety and Health Act, other safety rules, organization standards and regulations, etc.

**4** Do not handle, pipe, or remove devices before confirming safety.

- ① Inspect and service the machine and devices after confirming safety of all systems related to this product.
- ② Note that there may be hot or charged sections even after operation is stopped.
- ③ When inspecting or servicing the device, turn OFF the energy source (air supply or water supply), and turn OFF power to the facility. Discharge any compressed air from the system, and pay attention to possible water leakage and leakage of electricity.
- ④ When starting or restarting a machine or device incorporating pneumatic components, ensure in advance that system safety has been guaranteed, using, for instance, pop-out prevention measures.

**5** Observe the warnings and cautions on the following pages to prevent accidents.

■ Precautions given here are ranked as “DANGER”, “WARNING”, and “CAUTION”.

 **DANGER:** In the case where the product operation is mishandled and/or when the urgency of a dangerous situation is high, it may lead to fatalities or serious injuries.

 **WARNING:** A dangerous situation may occur if handling is mistaken, leading to fatal or serious injuries.

 **CAUTION:** A dangerous situation may occur if handling is mistaken, leading to minor injuries or property damage.

Note that some items indicated with “CAUTION” may lead to serious results depending on the conditions. All items contain important information and must be observed.

## Limited warranty and disclaimer

### 1 Warranty period

This warranty is valid for one (1.5) year after delivery to the customer's designated site.

### 2 Scope of warranty

In case any defect clearly attributable to CKD is found during the warranty period, CKD shall, at its own discretion, repair the defect or replace the relevant product in whole or in part and at no cost, according to its own judgment.

Note that the following failures are excluded from the warranty scope:

- (1) Failures due to use outside the conditions and environments set forth in the catalog or these specifications.
- (2) Failures resulting from factors other than this product.
- (3) Failures caused by improper use of the product.
- (4) Failures resulting from modifications or repairs made without CKD consent.
- (5) Failures caused by matters that could not be predicted with the technologies in practice when the product was delivered.
- (6) Failures resulting from natural disasters or accidents for which CKD is not liable.

The warranty covers the actual delivered product, as a single unit, and does not cover any damages resulting from losses induced by malfunctions in the delivered product.

### 3 Compatibility check

The customer is responsible for confirming the compatibility of CKD products with the customer's systems, machines and equipment.

## Precautions for export

### 1 Security Trade Control

The products in this catalog and their related technologies may require approval before export or provision.

For the sake of maintaining world peace and safety, there may be cases in which approval under the Foreign Exchange and Foreign Trade Control Law is required in advance, depending on the country to where the product or related technology is being exported or provided.

The scope of products and related technologies requiring approval is listed in the "Export Trade Control Order Appendix Table 1" or "Foreign Exchange Order Appendix Table". "The Export Trade Control Order Appendix Table 1" and "Foreign Exchange Order Appendix Table" contain the following two types of information:

- "List control", which is specified for each item 1 to 15
- "Catch-all controls" that do not indicate specifications by item, but restrict by application (Section 16)

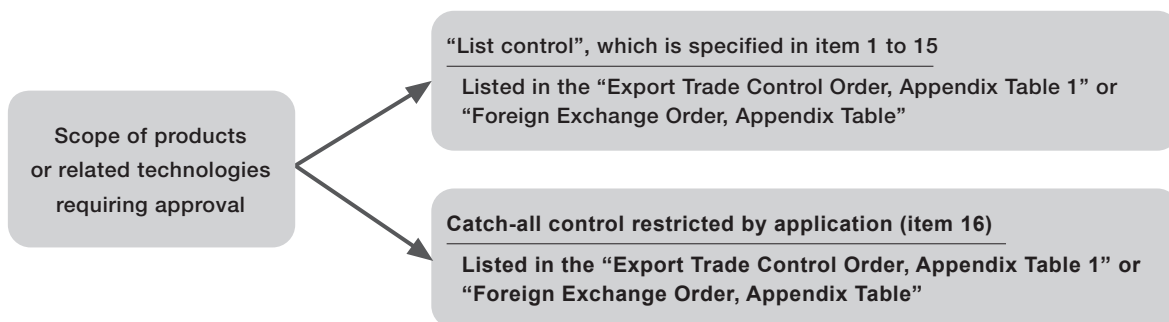

An application for approval is received by the Security Export Licensing Division of the Ministry of Economy, Trade and Industry, or a local bureau of the Ministry of Economy, Trade and Industry, according to the details about the combination of products, the related technology and destination for export, and the suppliers.

### 2 Products and related technologies in this catalog

The products and related technologies that appear in this catalog include those which are subject to the list of regulations in the Foreign Exchange and Foreign Trade Control Law.

Details about the product or related technology being subject to the list of regulations in the Foreign Exchange and Foreign Trade Control Law can be found on the corresponding product page.

Therefore, when exporting or supplying products or related technology which fall under the list of regulations, please obtain export authorization based on the Foreign Exchange and Foreign Trade Control Law.

In addition, when exporting or supplying the products or related technologies in this catalog, ensure that there is no risk of their use in applications relating to arms or weapons.

### 3 Contact

Contact your local CKD Sales Office for information on the Security Trade Control of products and related technologies in this catalog.



# Fine System devices Safety Precautions

Be sure to read this section before use.

## Design/selection

### 1. Checking the specifications

#### WARNING

- **This product cannot be used as an emergency shutoff valve.**  
The valves listed in this catalog are not designed as valves to ensure safety such as emergency shutoff valves. When using in such a system, always take separate measures that will ensure safety.
- **Incorrect equipment selection and handling can give rise to problems not only with this product, but also with your own system.** For equipment selection and handling, it is the customer's responsibility to check the specifications of this product and the compatibility with your system before use.
- **Working fluids**  
For information on the compatibility of product materials, working fluids, and ambient atmospheres, refer to the compatibility checklist on Intro Page 15 as a basic reference. For fluids not listed in the checklist or new fluids (including different concentration levels), contact and inquire with CKD beforehand.  
The PYM and PMM Series cannot be used with corrosive fluids. The PMM Series cannot be used for alcohol or solvents.
- **Fluid temperature**  
Be sure to use the coolant check valve within the specified fluid temperature range.
- **Fluid pressure range**  
Use within the fluid pressure range given in the specifications in the catalog.
- **Ambient environment**
  - (1) Use only after checking the compatibility of the product structural materials and the surrounding atmosphere. (Do not use in a corrosive or explosive atmosphere.)
  - (2) Do not allow fluid to come into contact with the product body.
  - (3) Use within the ambient temperature range.
  - (4) Do not use this product outdoors or in a place where it can be subjected to vibration or impact, or near a heat source.

### 2. Design

#### WARNING

- **When using a fluid that may be hazardous to humans, isolate the valve and ensure that no one can approach it.**
- **Liquid sealing**  
When the valve opens and closes, the diaphragm moves up and down, which accordingly causes the flow path capacity to change inside the valve. Therefore, because the fluid is incompressible (a liquid), operating under conditions that seal the fluid in the valve (liquid seal) will cause abnormal pressures to develop inside the valve. In this case, install a release valve on the primary or secondary side of the valve, preventing a liquid ring circuit from forming.

- **Securing maintenance space**  
Secure sufficient space for maintenance and inspection.
- **With the Rc screw type, although piping is done in accordance with Item (1) "Rc threaded portion case" below, the screwed in part may leak with thermal cycling, so when using under these conditions, select the integrated fitting type.**

### 3. Option with sensor

#### WARNING

- **Application, load current, voltage, temperature, impact, environment, etc., exceeding the specifications will result in damage or operation faults.** Use the device as instructed in specifications.
  - **Never use this product in an explosive gas atmosphere.** The sensor option does not have an explosive-proof structure. Never use in an explosive gas atmosphere, as explosions or fires could result.
  - **The sensor option has a structure which is neither dust-proof nor drip-proof.** It cannot be used in places with a lot of steam or dust, for example, or in places where it can be splashed directly by chemicals, or in such atmospheres as corrosive gas.
  - **Take care when using in an interlock circuit.**  
When using the sensor option for an interlock signal that requires high reliability, use a double interlock system that provides mechanical protection function to anticipate breakdown, for example, or that uses another sensor at the same time.  
Regularly inspect and confirm that the interlock activates correctly.
  - **Take care with the contact capacity.**  
Do not use a load that exceeds the sensor's maximum contact capacity. This may lead to failure.
  - **Take care with the protection circuit.**
    - When used with a connected inductive load (relay or solenoid valve), a surge voltage is generated when the sensor is turned off, so be sure to provide a protection circuit.
    - When connected to a capacitive load (capacitor), an inrush current is generated when the switch is turned on, so be sure to provide a protection circuit.
    - When wiring becomes too long, the wiring capacity will be reached, creating an inrush current and damaging or shortening the life of the sensor, so be sure to provide a protection circuit.
  - **Do not use in places with surge sources.**  
In situations where equipment installed near the sensor generates large surges (such as electric lifters, high frequency induction ovens, and motors), there is a risk that the sensor's internal circuit electronics could be degraded or damaged, so consider using anti-surge protection.
- #### CAUTION
- **Be careful of internal voltage drop due to serial connection.**
    - When used with several serial sensor connections, the voltage drop over the sensors is the sum of the voltage drops over all connected sensors. Determine the number of connections after checking the load specifications in order to ensure that the maximum load current for the sensor is not exceeded.



## Mounting, Installation and Adjustment

### 1. Installation

#### ⚠ WARNING

- Incorrect mounting and piping will result in problems with not only the product, but the user's system itself, and may result in death or serious injury. The user is responsible for making sure that the operator has read the instruction manual and fully comprehends the system, fluid characteristics, compatibility between the fluid and related products, and other safety-related information.

#### ⚠ CAUTION

- After installation, check for leaks from pipes, and that the installation has been carried out correctly.

### 2. Piping

#### ⚠ WARNING

- Always flush the piping before installing the valve. Fluid which has been contaminated with dirt or foreign matter may prevent the valve from functioning correctly. If there is contamination, install a filter on the primary side of the valve.
- For products displaying an arrow, be sure that the piping is performed so that the flow of the fluid is consistent with the direction of the arrow.
- When piping, do not apply tension, compression, bending or other forces from the piping on the valve body.
- For NC and NO types, ports that are not pressurized with operating pressure should be open to atmosphere. If direct intake and exhaust from the valve should be avoided due to reasons such as ambient atmospheric conditions or airborne dirt, remove the set screw and install piping in order to allow intake and exhaust elsewhere as preferable.
- Use the driving solenoid valve connected to the drive unit according to the specifications or applications.

#### ⚠ CAUTION

- With the fittings for PFA tubes, refer to the latest instruction manual issued by each individual fitting manufacturer, and be sure to follow the information provided.

As dedicated work jigs are required for fitting work, contact each fitting manufacturer separately.

In the case of AMG, GAMD, and GMMD, note that the fittings are close together, and work may be difficult with regular tools. Consult with CKD when the fitting manufacturers' dedicated work jigs cannot be used. (Super 300 Type Pillar fitting and Final Lock fitting)

- When working on the union fitting, check that the O-ring fits correctly into the groove on the body of the union nut, and tighten it completely until the O-ring is crushed. If it has not been thoroughly tightened, it is dangerous as the fluid may leak to the outside.
- When welding a PFA pipe projection used for welding, have the work done by a specialist in PFA pipe welding.
- When installing piping, avoid applying any stress on the valve body itself, such as bending, tension, or compression. Also, check that neither the support position of the pipes nor the method used add piping load on the valve.
- Fix the equipment to the mounting plate in addition to using fittings as support when installing a valve.
- Follow the procedure given below when working on the Rc threaded portion.

#### (1) For Rc threaded portion

(1) Wrap PTFE sealing tape three or four times around a fitting which is compatible with the JIS B 0203 pipe taper screw.

(2) Tighten at the following torque.

Port size	PFA fitting	PVC fitting
Rc1/8	0.5 to 0.8	—
Rc3/8	1.0 to 1.5	—
Rc1/2	1.5 to 2.0	2.0 to 2.5
Rc3/4	2.0 to 2.5	2.5 to 3.0
Rc1	2.5 to 3.5	3.0 to 4.0

(N·m)

#### (2) Operating port

Tighten to 0.4 to 0.6N·m to avoid the risk of cracking the port or damaging the screw thread.

When using metal or PPS fittings with AMD3/4/5\*2, AMG3/4/502, or GAMD3/4/5\*2, select one with a reinforcing ring (refer to the page for each individual model).

Do not use a metal fitting with AMD4/5/61H or AMD3/51M.



## Fine System devices

# Safety Precautions

Be sure to read this section before use.

## Mounting, Installation and Adjustment

### 3. Option with sensor

#### CAUTION

##### ■ Do not drop or apply impact.

Take care not to drop products with sensors when handling, bump them into anything, or subject them to excessive shock. Even if the body is not damaged, sensor components could break or malfunction.

##### ■ Do not carry the valve body around by the lead wire on the sensor.

This can not only disconnect the lead wire, but also exert stress on the sensor interior, damaging the internal sensor components.

##### ■ Do not install wiring in series with power lines or high voltage lines.

Avoid wiring parallel to or in the same conduit with power lines or high voltage lines. The control circuit containing the sensor could malfunction due to noise.

##### ■ Avoid short-circuiting the load.

Overcurrent will flow if turned on with the load short-circuited, and this will damage the sensor.

##### ■ Take care with the lead wire connection.

Turn OFF power to the device in the electric circuit to be connected before starting wiring. Doing work on the device while the power supply is on can lead to accidents involving electric shocks or unpredictable behavior.

##### ■ Check that the fluctuations in the input power supply do not exceed the rated value.

##### ■ When using a commercially available switching regulator for the power supply, be sure to ground the frame ground (F.G.) terminal on the power supply.

##### ■ When using a device which could be a source of noise near the sensor (such as a switching regulator or inverter motor), be sure to ground the frame ground (F.G.) terminal on the device.

### 4. MNV Series electric needle valves

#### WARNING

##### ■ The surface of the product will reach high temperatures when used under high temperature conditions. There is a risk of burns, etc. if touched directly.

##### ■ Operating valve A releases a tiny amount of permeated gas from the chemical liquid from the breathing hole located on the side of the cover. Do not put your face or hand near the breathing hole. When touching the valve, use corrosion-resistant gloves to avoid making contact with bare hands.

## Use/maintenance

### 1. Before use

#### ⚠ WARNING

- Use within the max. operating pressure and max. working pressure ranges.

#### ⚠ CAUTION

- Do not disassemble.
- Do not subject the product to strong impact from dropping or similar mishandling. This may cause damage or breakdown of the product.
- For information on the compatibility of product materials, working fluids, and ambient atmospheres, refer to the compatibility checklist on Intro Page 15 as a basic reference. For fluids not listed in the checklist or new fluids (including different concentration levels), contact and inquire with CKD beforehand.
  - With fluids containing particles, such as slurry or UV curing agents, or those prone to solidification or gelling, this may sometimes have an effect on the performance.
  - Fluids containing a surfactant, stripping solution, and so on, that possess a high permeability, may actually permeate the parts themselves.

Conduct periodic inspections, and if there is any abnormality, take necessary measures such as replacing the parts.

- Gases such as N<sub>2</sub> gas or air may leak from the valve seat by a maximum of 1 cm<sup>3</sup>/min (at air pressure).
- Rapid changes in fluid temperature may cause the valve seat to deform unevenly and allow it to leak.
- For the operating air, use air which has been passed through a filter with a filtration rating performance of 5 μm or more, or alternatively, an inert gas.
- Take care when handling, as the product is minutely cleaned and packed before delivery, under the assumption that installation will take place inside a clean room.
- Do not overly tighten the knobs on the flow rate adjuster or bypass adjuster.
- Do not use valves as footing or place any heavy objects on top of the valves.
- If the product has been out of use for a long time, perform a test run before starting actual operation.
- Turbulent flow occurs on the secondary side of the valve. When installing a device that requires laminar flow, e.g. a flow rate meter, on the secondary side of the valve, make sure to keep enough distance between the valve and the device so that the device is not affected by the turbulent flow.

- Never attempt to disassemble the product. It is very dangerous, as some products include high-load springs.
- Do not allow fluid to come into contact with the body of the product.

### 2. Option with sensor

#### ⚠ WARNING

##### ■ Do not apply overcurrent.

If overcurrent flows due to a short-circuited load, etc., there is a risk of fire as well as damage to the sensor. Provide an overcurrent protection circuit, such as a fuse, for the output wire and power cable as needed.

#### ⚠ CAUTION

##### ■ Pay attention to the reverse current caused by wire disconnection/wiring resistance.

- If other devices including sensors are connected to the same power supply, when the output wire and power cable negative (-) side are short-circuited to check the operation of the control panel's input unit, or when the power cable's negative (-) side is disconnected, reverse current could flow to the flow rate sensor's switch output circuit and cause damage.

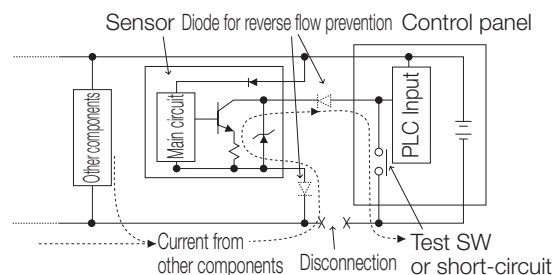

- Take the following measures to prevent damage caused by reverse current.
  - (1) Avoid centralizing current at the power cable, especially at the negative side, and use as thick a cable as possible.
  - (2) Limit the number of devices connected to the same power source as the flow rate sensor.
  - (3) Insert a diode in series with the flow rate sensor's output line to prevent reverse current.
  - (4) Insert a diode in series with the sensor power line negative (-) side to prevent the current reversing.

##### ■ Pay attention to surge current leading.

- When the power supply for the sensor is shared with an inductive load that generates surges, such as a solenoid valve or relay, if the circuit is cut off while the inductive load is functioning, surge current could enter the switch output circuit and cause damage depending on where the surge absorbing element is installed.

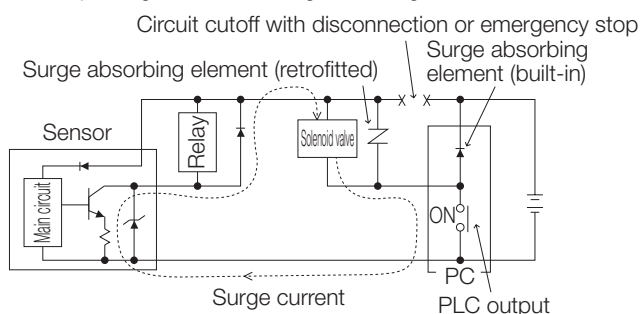





# Fine System devices Safety Precautions

Be sure to read this section before use.

## Use/maintenance

- Take the measures below to prevent damage from sneak surge current.
- (1) Separate the power supply for output including the inductive load, such as the solenoid valve and relay, and input, such as the sensor.
- (2) If a separate power supply cannot be used, directly install a surge absorption element for all inductive loads. Consider that the surge absorption element connected to the PLC, etc., protects only the individual device.
- (3) Insert a diode in series with the flow rate sensor's output line to prevent reverse current.
- (4) Connect a surge absorption element to places on the power wiring shown in the figure below, as a measure against disconnections in unspecified areas.

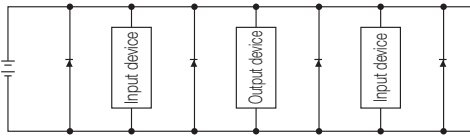

When the devices are connected to a connector, the output circuit could be damaged by the above phenomenon if the connector is disconnected while the power is ON. Turn power OFF before connecting or disconnecting the connector.

### 3. Air operated/manual valve AMD/MMD Series for chemical liquids

#### CAUTION

- When using the MMD Series or AMD Series with flow rate adjustment, turn the adjusting dial to at least the minimum number of times past the fully closed state. If used below this level, vibration or flow rate fluctuation may occur depending on the working conditions. Changes in fluid temperature may also affect flow rate depending on operating conditions (see pages 114 to 119).  
Use the MMD\*\*2 Series in either the fully closed or fully open state. Cannot be used in intermediate positions. Tighten the knob for the MMD\*\*2 Series within the torque range shown given in the table below. If the knob is loose, it may turn due to the vibration of the pump.

Model No.	MMD302	MMD402	MMD502
Knob tightening torque	0.8 to 1.5	1.0 to 1.8	1.5 to 2.5

(N·m)

### 4. Air operated valve AMD/GAMD Series for chemical liquids

#### CAUTION

- With the AMD/GAMD Series, water hammer and vibration may occur under certain fluid pressure conditions. In most cases, this can be resolved by adjusting the open-close speed using a speed controller, etc. If a problem persists, review and revise the fluid pressure and piping conditions.

### 5. Air operated/manual valve AMD\*1H/MMD\*0H Series for chemical liquid supply Air operated/manual valve AMD\*1M/MMD\*0M Series for chemical liquid

#### CAUTION

- To recover permeated gas from the diaphragm or to detect leaks, remove the set screw and use the detection port as a piping port. Tighten the piping to 0.4N·m or less for use with fluororesin.  
Use the MMD\*0H and MMD\*0M Series in either the fully open or fully closed state. Cannot be used in intermediate positions.

### 6. Fine regulator PMM/PYM/PMP Series

#### CAUTION

- In the PMM, PYM, and PMP Series, fluctuations in fluid pressure, flow rate, supply pressure, piping, etc. may cause vibrations that could shorten product life. If a problem arises, revise the fluid pressure and flow rate conditions.
- As the regulator uses a minuscule aperture, fluids contaminated with foreign matter could damage the valve seat, lowering performance. If there is a risk of foreign matter entering the fluid, we recommend installing a filter on the primary side of the regulator.
- When the set output pressure of the regulator is exceeded, if damage and malfunction of devices at the secondary side could be caused, always provide a safety device.

### 7. Maintenance and inspection

#### DANGER

- When replacing the valve, thoroughly replace the remaining chemical liquid with pure water or air so that it does not affect the surrounding devices and humans.

While the upper side of the diaphragm (cylinder side) does not come into contact with the fluid, it is exposed to a chemical liquid atmosphere due to gas permeation from the thin film part.

For your safety, follow the precautions below:

- (1) Since a small amount of permeated gas is released from the breathing hole located on the side of the cylinder due to valve operation, ensure that no one approaches the breathing hole during valve operation.
- (2) Crystals may also adhere to the breathing hole or around it.
- (3) When touching the valve, use corrosion-resistant gloves to avoid making contact with bare hands.

## Use/maintenance

- Valves used with chemical liquids may have chemical atmosphere remaining between the actuator and the diaphragm. Never attempt to disassemble the product.  
If disassembly is necessary, contact CKD or a dealership.
- Perform the following periodic inspection once or twice a year to ensure that the valve is achieving optimal functionality.
  - (1) Check for leaks to the valve exterior
  - (2) Check for leaks from the fitting
  - (3) Check for anomalies such as discoloration, deformation, or corrosion

### WARNING

- Read the instruction manual thoroughly and make sure you understand the content before performing maintenance.
- Always drain the operating air and fluid before carrying out maintenance.
- Before starting maintenance or inspection, read the material safety data sheet (MSDS) for the chemical liquid used and wear the necessary protective gear.
- If chemical liquids such as hydrochloric acid, hydrofluoric acid, or nitric acid are used over prolonged periods, their high permeability can also lead to the deterioration of parts besides the wetted parts through gas permeation, leading to accidents such as leaks. In the interests of safety, check once or twice a year for anomalies such as discoloration, deformation, or corrosion of constituent components.

### CAUTION

- When replacing a product, always replace it with one of the same model number. Specifications may differ even when the appearance is the same.
- Store unused products in a location where they are not exposed to direct sunlight or high temperatures. When handling the product, do not apply impact or damage it by throwing, dropping, or allowing it to catch on something.



# Fine System devices Safety Precautions

Be sure to read this section before use.

## Product and working fluid compatibility checklist

\* This checklist is created based on previous evaluations and experience, and does not guarantee performance.

\* When using chemicals that are not entirely pure, check with a chemical expert about the compatibility of the working fluid with the materials in the product to decide if it is advisable for use.

Fluid name		Principal use: Cleaning equipment/Chemical liquid supply equipment												
		Air operated valve						Manual valve						
		2-port			3-port			Manifold			2-port			
		AMDZ*3R AMD3*3R AMD4*3R AMD5*3R	AMD0*2	AMD3*2 AMD4*2 AMD5*2	AMD41H AMD51H AMD61H	AMD31M AMD51M	AMGZ03R AMG303R AMG403R AMG503R	AMG3*2 AMG4*2 AMG5*2	GAMDZ*3R GAMD3*3R GAMD4*3R GAMD5*3R	GAMD0*2A	GAMD3*2 GAMD4*2 GAMD5*2	MMD302 MMD402 MMD502	MMD40H MMD50H MMD60H	MMD30M MMD50M
Pure water		●	●	●	●	●	●	●	●	●	●	●	●	
Oxidizing fluids	Sulfuric acid	●	●	●	●	●	●	●	●	●	●	●	△	
	Hydrochloric acid	●	●	● (Note 10)	●	●	● (Note 10)	●	●	●	● (Note 10)	●	●	
	Nitric acid	●	● (Note 5)	● (Note 5)	●	●	● (Note 5)	●	△	● (Note 5)	●	●	●	
	Hydrofluoric acid (Note 2)	● (Note 11)	●	● (Note 5,10)	●	●	● (Note 11)	● (Note 5,10)	● (Note 11)	●	● (Note 5)	● (Note 5,10)	●	
	Phosphoric acid	●	●	●	●	●	●	●	●	●	●	●	●	
	Ammonium fluoride (Note 2)	● (Note 11)	●	● (Note 5)	●	●	● (Note 11)	● (Note 5)	● (Note 11)	●	● (Note 5)	● (Note 5)	△	
	Hydrogen peroxide	●	●	●	●	●	●	●	●	●	●	●	●	
	Ozone water	△	△	△	△	△	△	△	△	△	△	△	×	△
Sulfuric acid + Hydrogen peroxide (Note 3)	●	●	●	●	●	●	●	●	●	●	●	●	△	
Sulfuric acid + Ozone	△	△	△	△	△	△	△	△	△	△	△	×	△	
Basic fluids	Sodium hydroxide	●	●	●	●	●	●	●	●	●	●	●	△	
	Potassium hydroxide	●	●	●	●	●	●	●	●	●	●	●	△	
	Aqueous ammonia	●	● (Note 6)	● (Note 6)	● (Note 6)	△	●	● (Note 6)	●	● (Note 6)	● (Note 6)	● (Note 6)	● (Note 6)	△
Organic fluids	Acetone	×	● (Note 6)	● (Note 7)	● (Note 6)	- (Note 8)	×	● (Note 6)	×	● (Note 6)	● (Note 6)	● (Note 7)	● (Note 6)	- (Note 8)
	Butyl acetate	×	● (Note 6)	● (Note 7)	● (Note 6)	- (Note 8)	×	● (Note 6)	×	● (Note 6)	● (Note 6)	● (Note 7)	● (Note 6)	- (Note 8)
	Isopropyl alcohol	●	●	●	●	- (Note 8)	●	●	●	●	●	●	●	- (Note 8)
Others/ Liquid mixtures (Note 1)	Paint thinner	×	●	●	●	- (Note 8)	×	●	×	●	●	●	●	- (Note 8)
	Resist	●	●	●	●	- (Note 8)	●	●	●	●	●	●	●	- (Note 8)
	Developing solution	●	●	●	●	- (Note 8)	●	●	●	●	●	●	●	- (Note 8)
	Slurry	●	●	●	●	- (Note 8)	●	●	●	●	●	●	●	- (Note 8)
	Plating solution	●	●	●	●	- (Note 8)	●	●	●	●	●	●	●	- (Note 8)
Stripping solution (Note 4)	●	●	●	●	- (Note 8)	●	●	●	●	●	●	●	- (Note 8)	
Gas	Air/nitrogen gas	Gases may leak from the valve seat by a maximum of 1cm <sup>3</sup> /min (at air pressure).												

Judgment	●	Usable. (Check details on the product page.)
	△	Contact CKD for details. (May be usable depending on the conditions.)
	×	Unusable.

Note 1 : As there are many possible mixtures of various chemical liquids, it is not possible to understand all effects.

Decide on the advisability of use after thoroughly checking the compatibility of the constituent materials in the product and the fluids used.

Note 2 : When using hydrofluoric acid, or chemical liquids that contain hydrofluoric acid, consult with CKD if you intend to exceed a fluid temperature of 40°C.

Note 3 : Consult with CKD if you intend to use a sulfuric acid + hydrogen peroxide solution above 100°C.

Note 4 : If you are using an amine system stripping solution at fluid temperatures of 80°C or above, replace it periodically.

Consider a minimum of once a year as a guideline.

Note 5 : Select Option "P".

Note 6 : Select Option "M".

Note 7 : Select a stainless steel body type if metal piping is being used.

Select Option "M" for fluororesin piping.

Note 8 : We recommend using the AMD\*\*H Series or the AMD\*\*2 Series, which are suited for these types of chemical liquids.

Note 9 : As these are chemical liquids of high permeability, it is possible that permeated gas could mix with the pilot air and compromise the operating device.

















Consult with CKD if the operating device needs to be protected.

Note 10: Support can be provided with custom-made orders that include measures against oxidizing fluids and permeated gas. Contact CKD separately.

Note 11: When using hydrofluoric acid, or chemical liquids that contain hydrofluoric acid, the fluid temperature should be 5 to 80°C.

Cannot be used with a body that includes a bypass.

Note 12: Gases may leak from the valve seat by a maximum of 1cm<sup>3</sup>/min (by air pressure).

Principal use: Cleaning equipment/Chemical liquid supply equipment						Principal use: Coater/developer				Peripheral devices					
Manual valve		Flow rate adjusting valve		Sister products		Air operated valve		Manual valve	Air operated valve drip prevention valve/ Drip prevention Valve integrated type	Fine regulator					
Manifold	Toggle valve	Manual type	Electric type	Air operated valve	Manual valve	2-port	3-port	Toggle valve		Pilot operated type		Manual type			
GMMD302 GMMD402 GMMD502  .....Page 144	TMD302  .....Page 156	FMD00  .....Page 162	MNV  .....Page 166	AMD2* AMD3* AMD4* AMD5*  .....Page 106	MMD20 MMD30 MMD40  .....Page 152	AMDZ* AMD0*  .....Page 18	AMGZ0 AMG00  .....Page 68	TMDZ02 TMD002  .....Page 156	AMSZ2 AMS022  .....Page 170 AMDSZ0 AMDS00  .....Page 174	PMP202  .....Page 180	PMP402  .....Page 180	PYM10  .....Page 184	PMM20  .....Page 186	PMM50  .....Page 188	
●	●	●	●	●	●	●	●	●	●	●	●	●	●	●	●
●	●	●	●	●	●	x	x	x	△	●	△ (Note 10)	x	x	x	
● (Note 10)	△	●	x	●	△	x	x	x	△	△ (Note 9)	△ (Note 10)	x	x	x	
●	△	●	x	●	△	x	x	x	△	△ (Note 9)	△ (Note 10)	x	x	x	
● (Note 5,10)	△	●	x	●	△	x	x	x	△	△ (Note 9)	△ (Note 10)	x	x	x	
●	●	●	●	●	●	x	x	x	△	●	△ (Note 10)	x	x	x	
● (Note 5)	△	●	x	●	△	x	x	x	△	● (Note 9)	△ (Note 10)	x	x	x	
●	△	●	●	●	△	x	x	x	△	●	△ (Note 10)	x	x	x	
△	x	x	x	x	x	x	x	x	△	△	△ (Note 10)	x	x	x	
●	△	●	●	●	△	x	x	x	△	●	△ (Note 10)	x	x	x	
△	x	x	x	x	x	x	x	x	△	△	△ (Note 10)	x	x	x	
●	●	●	△	●	●	●	●	●	●	●	△	△	△	x	
●	●	●	△	●	●	●	●	●	●	●	△	△	△	x	
● (Note 6)	●	●	x	● (Note 6)	●	△	△	●	△	△ (Note 9)	△ (Note 10)	△	x	x	
● (Note 6)	△	x	x	x	x	●	●	△	●	△	△	△	△	x	
● (Note 6)	△	x	x	x	x	●	●	△	●	△	△	△	△	x	
●	●	●	x	●	●	●	●	●	●	●	●	△	△	x	
●	△	x	x	x	x	●	●	△	●	△	△	△	△	x	
●	△	x	x	x	x	●	●	△	●	●	△	△	△	x	
●	●	●	x	●	●	●	●	△	●	●	△	△	△	x	
●	●	●	x	●	●	△	△	△	△	●	△	△	△	x	
●	●	●	x	●	●	x	x	x	△	●	△ (Note 10)	x	x	x	
●	△	△	x	x	x	●	●	△	●	●	△	△	△	x	

Gases may leak from the valve seat by a maximum of 1cm<sup>3</sup>/min (at air pressure).

### ■ Metal piping/Stainless steel body

- Select a stainless steel body for metal piping.  
(Consult with CKD about models with no stainless steel body option. Support may be available depending on the model.)
- A stainless steel body cannot be used for oxidizing fluids.

### ■ Precautions concerning safety and performance

- When using organic solvents with fluororesin piping, apply a treatment to prevent ignition from static electricity.
- With fluids containing particles, such as slurry or UV curing agents, or those prone to solidification or gelling, this may sometimes have an effect on the performance.
- If the fluid has high permeability, such as fluids that contain a surfactant or stripping solution, the fluid may permeate through the parts.
- If chemical liquids such as hydrochloric acid, hydrofluoric acid, or nitric acid are used over prolonged periods, their high permeability can also lead to the deterioration of parts besides the wetted parts through gas permeation.
- In the interests of safety, check once or twice a year for anomalies such as discoloration, deformation, or corrosion of constituent components.

### Dimensions

● Fitting integrated type

- AMD<sup>4</sup><sub>5</sub> 1H-\*BJ
- AMD<sup>6</sup><sub>6</sub> \*BW

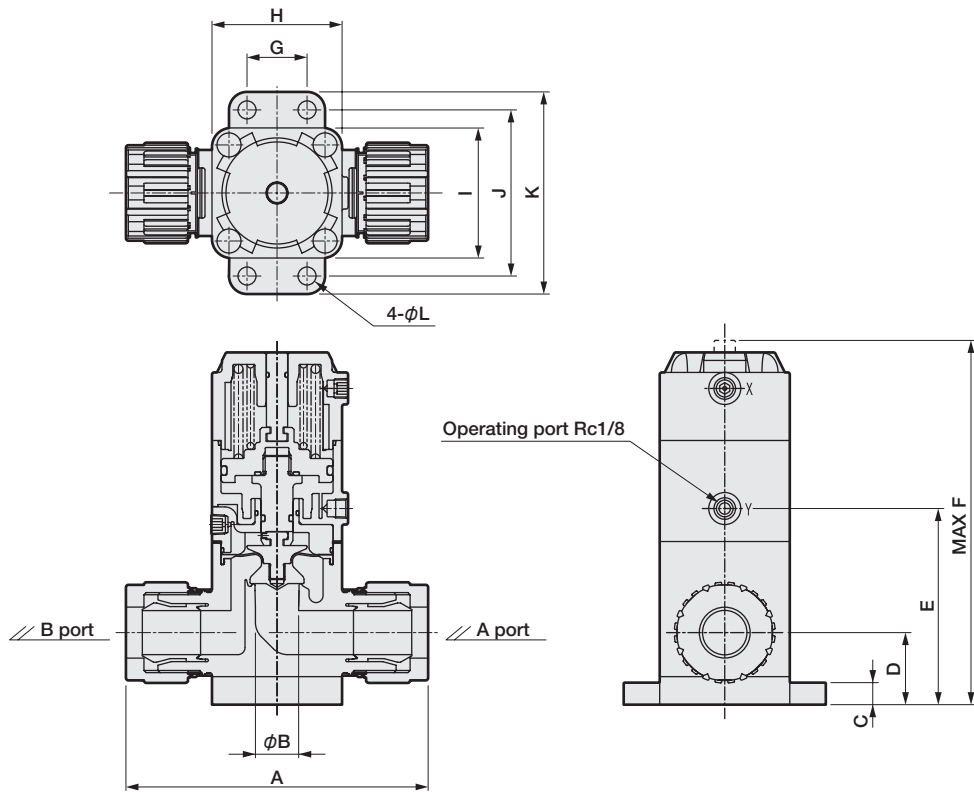

● Pipe type for welding

- AMD<sup>4</sup><sub>5</sub> 1H-\*W

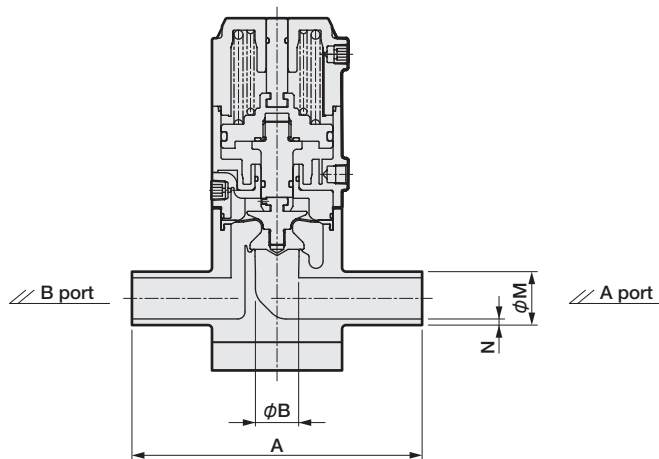

Model No.	Connection model No.	A	B	C	D	E	F	G	H	I	J	K	L	M	N
AMD41H	4BJ	108	10	10	31	80	147	20	50	50	68	86	9	-	-
	4BW	117	10	10	31	80	147	20	50	50	68	86	9	-	-
	2W	110	10	10	31	80	147	20	50	50	68	86	9	13.7	2.3
	6BJ	122	16	10	31	80	147	20	50	50	68	86	9	-	-
	6BW	126	16	10	31	80	147	20	50	50	68	86	9	-	-
	4W	130	16	10	31	80	147	20	50	50	68	86	9	21.3	2.8
AMD51H	8BJ	151	22	11	36	98	182	30	65	65	83	101	9	-	-
	8BW	161	22	11	36	98	182	30	65	65	83	101	9	-	-
	6W	145	22	11	36	98	182	30	65	65	83	101	9	26.7	2.9
AMD61H	10BJ	198	25	12	42	111	202	38	75	75	93	111	9	-	-
	8W	155	25	12	42	111	202	38	75	75	93	111	9	33.4	3.4





Air operated valve for chemical liquids, metal-free type

# AMD\*1M Series

A valve designed to be capable of dealing with the strong acid line (hydrochloric, hydrofluoric, nitric) in semiconductor manufacturing lines.

- Orifice size:  $\phi 8/\phi 10/\phi 16/\phi 22$



**Export controlled items**

\* Applicable item: Orifice size of  $\phi 16$  or larger

## Specifications

Descriptions	AMD31M		AMD51M	
	Actuation	NC (normally closed type)		
Working fluid	Chemical liquids/pure water (Note 1)			
Fluid temperature °C	5 to 40			
Proof pressure MPa	1.0			
Operating pressure (A→B) MPa	0 to 0.5			
Valve seat leakage cm <sup>3</sup> /min	0 (water pressure)			
Back pressure MPa	0 to 0.5			
Ambient temperature °C	0 to 40			
Frequency	20 times/min. or less		15 times/min. or less	
Mounting orientation	Unrestricted			
Connection	OD $\phi 3/8$ " tube connection OD $\phi 10$ tube connection	OD $\phi 1/2$ " tube connection OD $\phi 12$ tube connection	OD $\phi 3/4$ " tube connection	OD 1" tube connection OD $\phi 25$ tube connection
Orifice size	$\phi 8$	$\phi 10$	$\phi 16$	$\phi 22$
Cv	1.25	1.8	5.5	9.5
Operating section	Operating pressure MPa	0.4 to 0.6		
	Operating port	Rc1/8		

Note 1: Check the compatibility of product structural materials with the working fluids and ambient atmosphere. (Refer to the compatibility check list on Intro Page 15.)

Be sure to read the usage precautions on Intro Pages 7 to 16.

### Internal structure and parts list

AMD31M

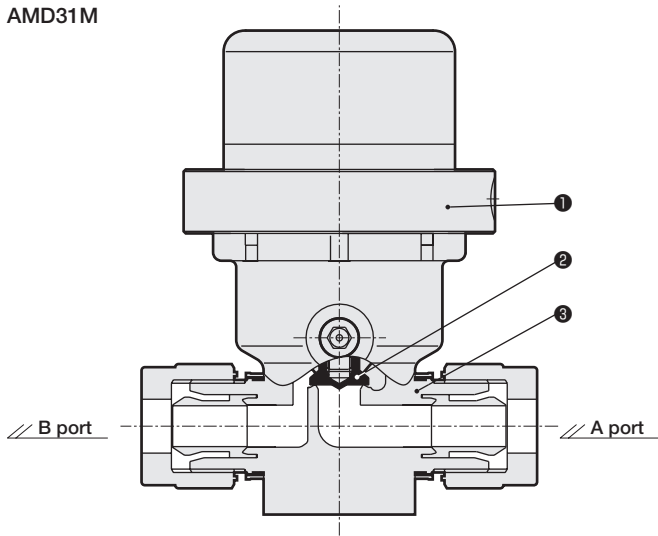

No.	Part name	Material
1	Actuator	PP and others
2	Diaphragm	PTFE
3	Body	PFA

AMD51M

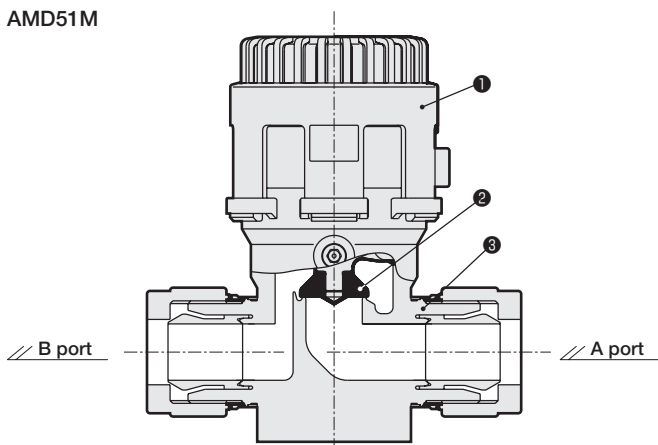

No.	Part name	Material
1	Actuator	PVDF and others
2	Diaphragm	PTFE
3	Body	PFA

AMD*3R
AMD*3R
AMD*0
AMD*2
AMD*3*2
AMD*4*2
AMD*5*2
AMD*1H
AMD*1M
AMG*03R
AMG*03R
AMG*0
AMG*02
GAMD*3R
GAMD*3R
GAMD*2A
GAMD*+2
High pressure specifications
AMD
Flow characteristics
MMMD*02
MMMD*0H
MMMD*0M
GMMMD*02
MMMD*+0
TMD*02
FMD*00
MNV
AMS
AMDS
Fine regulator
KML
Others
Related

# AMD\*1M Series

## How to order

●AMD\*1M series



Model No.

Ⓐ Connection

		AMD31M				AMD51M		
		Ⓐ Connection						
		3BJ	10J	4BJ	12J	6BJ	8BJ	25J
		Super 300 fitting P Series integrated type						
		3/8" x 1/4" tube connection	φ 10 x φ 8 tube connection	1/2" x 3/8" tube connection	φ 12 x φ 10 tube connection	3/4" x 5/8" tube connection	1" x 7/8" tube connection	φ 25 x φ 22 tube connection
Content	Orifice size	φ8		φ10		φ16		φ22
Cv		1.25		1.8		5.5		9.5

### Dimensions

#### ●AMD31M- \*1

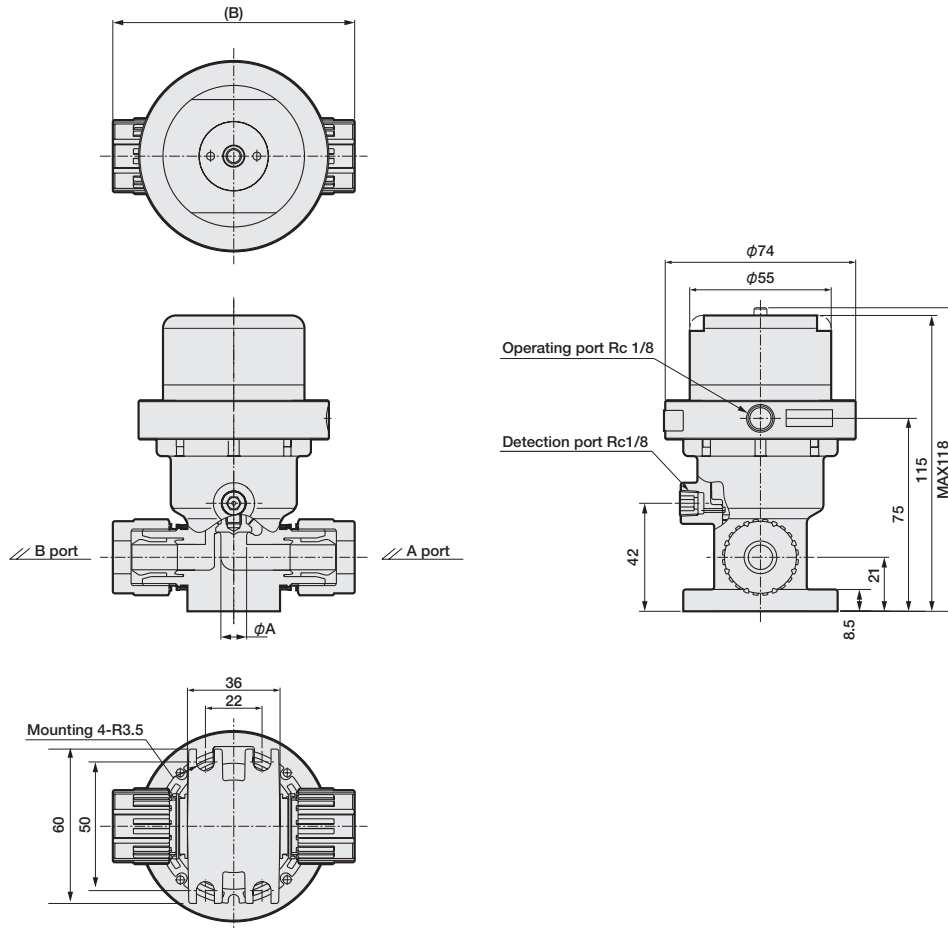

*1 (Connection model No.)	φA	B
3BJ	8	86
4BJ	10	94

#### ●AMD51M- \*1

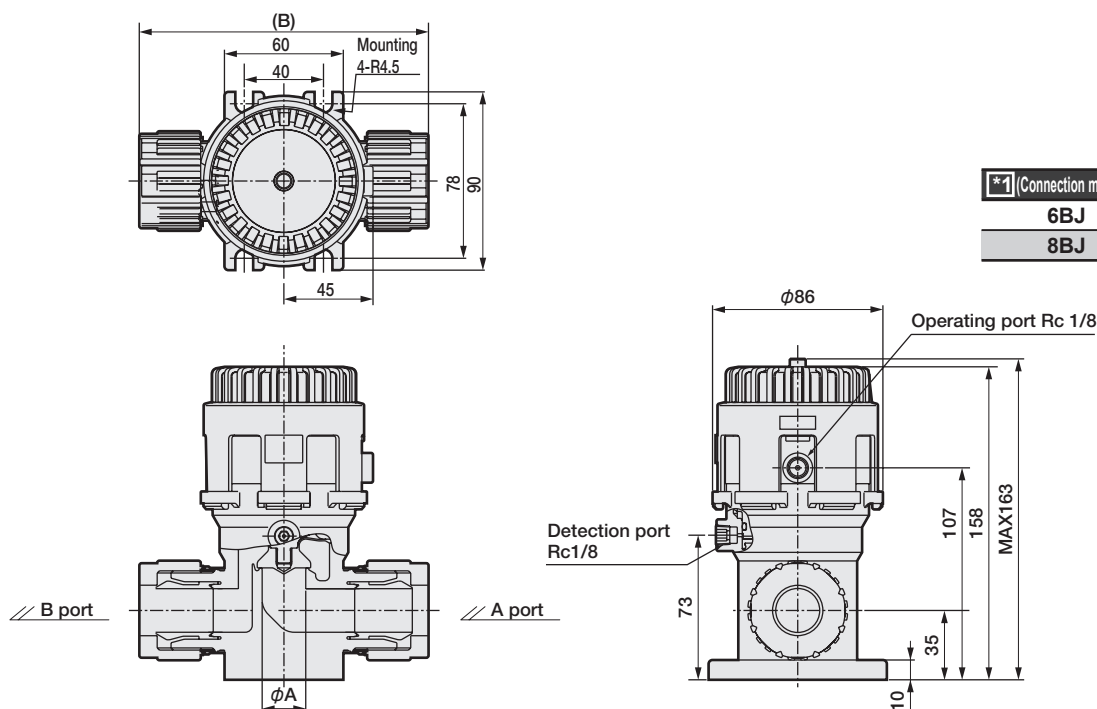

*1 (Connection model No.)	φA	B
6BJ	16	132
8BJ	22	146

# Fine System devices

## Flow characteristics

### AMDZ\*3R to AMD5\*3R

- Flow rate characteristics (water)  
Differential pressure vs. flow rate, Cv value in ( )

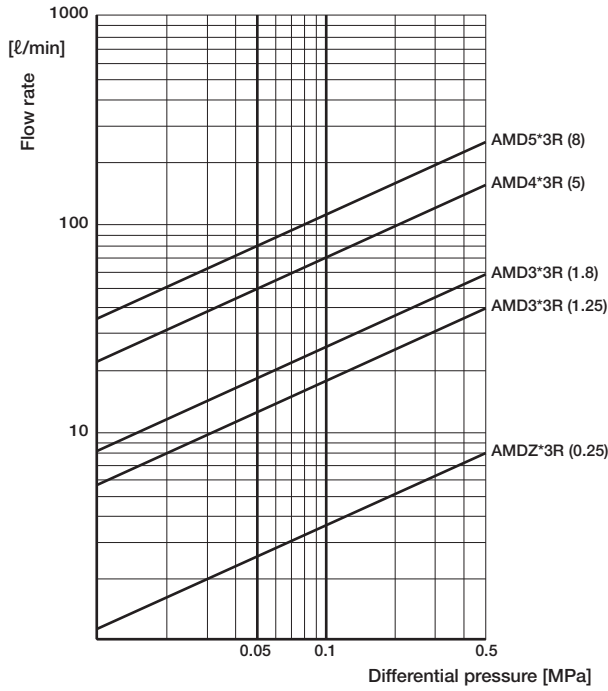

- Flow rate adjustment (water)  
No. of rotations vs. flow rate

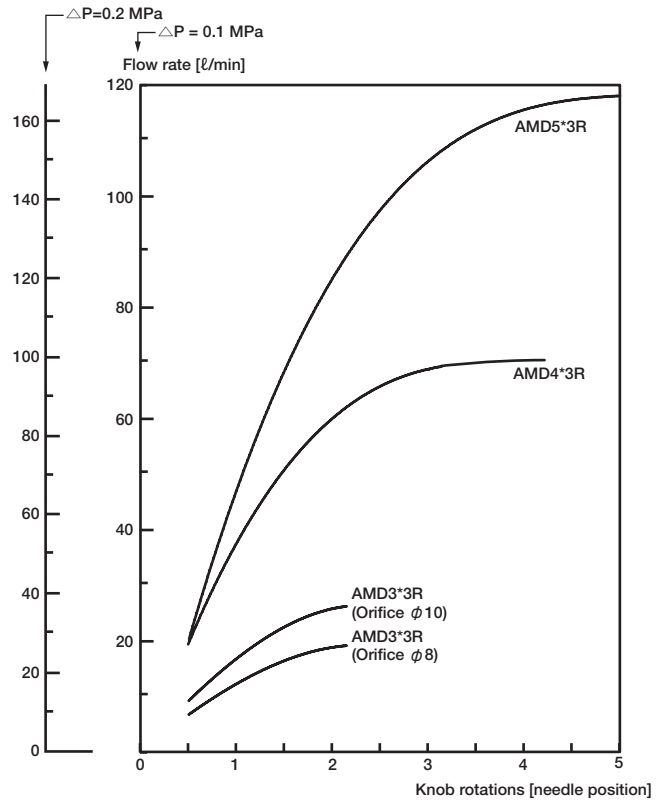

Note 1: Open the adjusting knob at least 1/2 turn from the completely closed state. If used below this level, vibration or flow rate fluctuation may occur depending on the working conditions.

- Bypass section Flow rate characteristics (water)  
Differential pressure vs. flow rate, Cv value in ( )

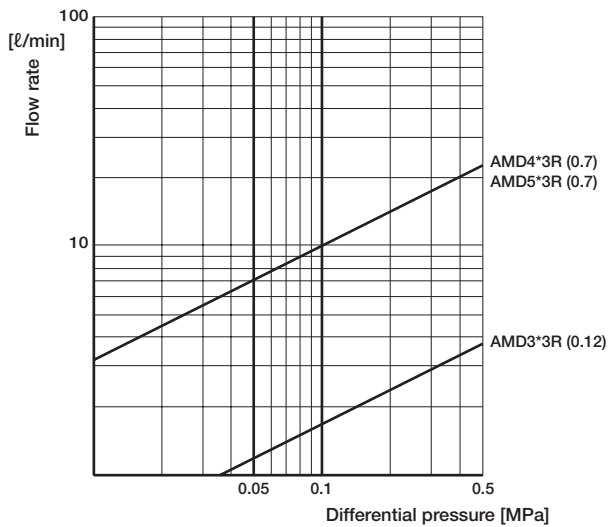

- With bypass (water)  
No. of rotations vs. flow rate

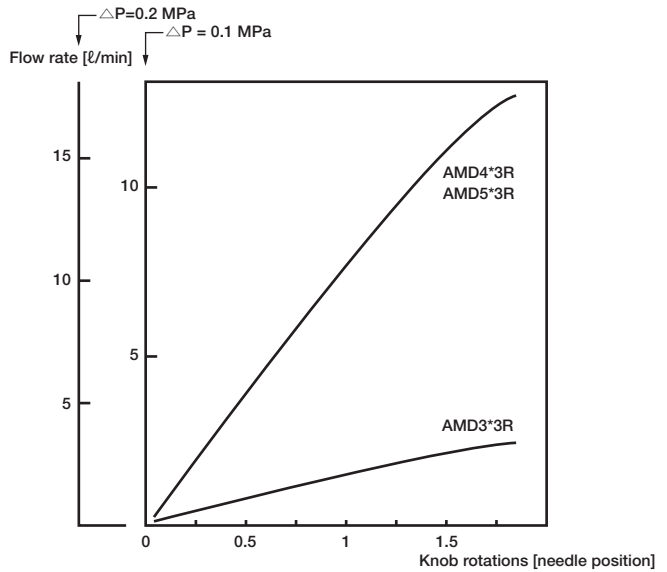



### Flow characteristics

#### AMD0□2 to AMD5□2

● Flow rate characteristics (water)  
Differential pressure vs. flow rate, Cv value in ( )

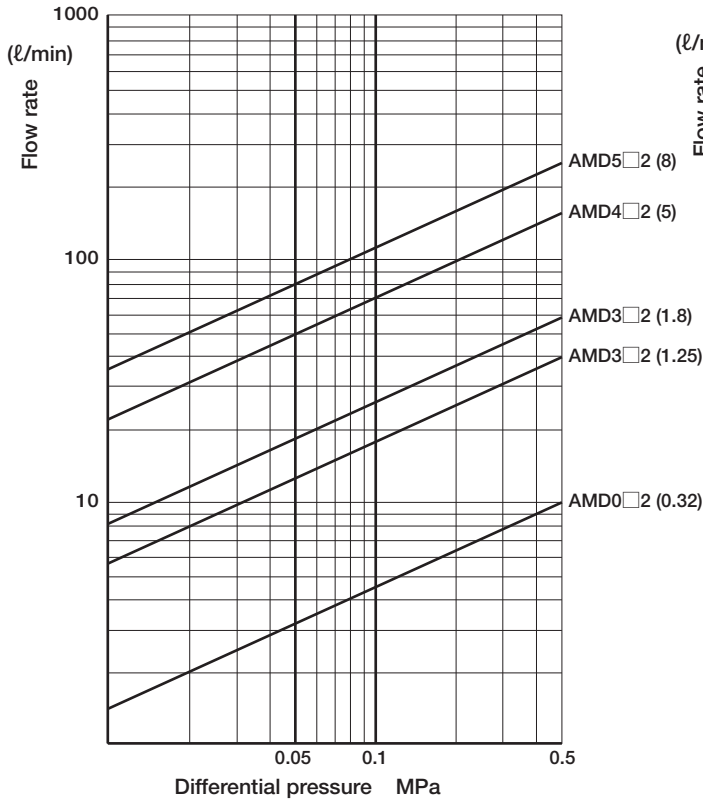

● Bypass section Flow rate characteristics (water)  
Differential pressure vs. flow rate, Cv value in ( )

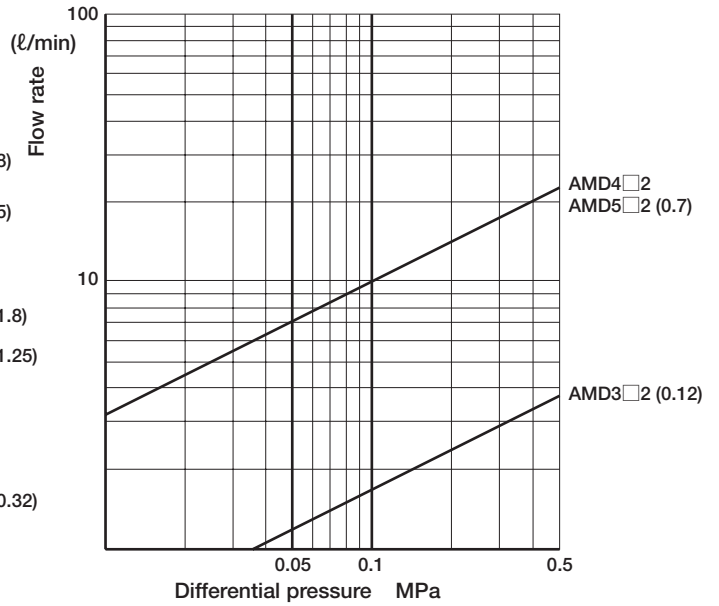

#### For liquid supply AMD41H to AMD61H

● Flow rate characteristics (water)  
Differential pressure vs. flow rate, Cv value in ( )

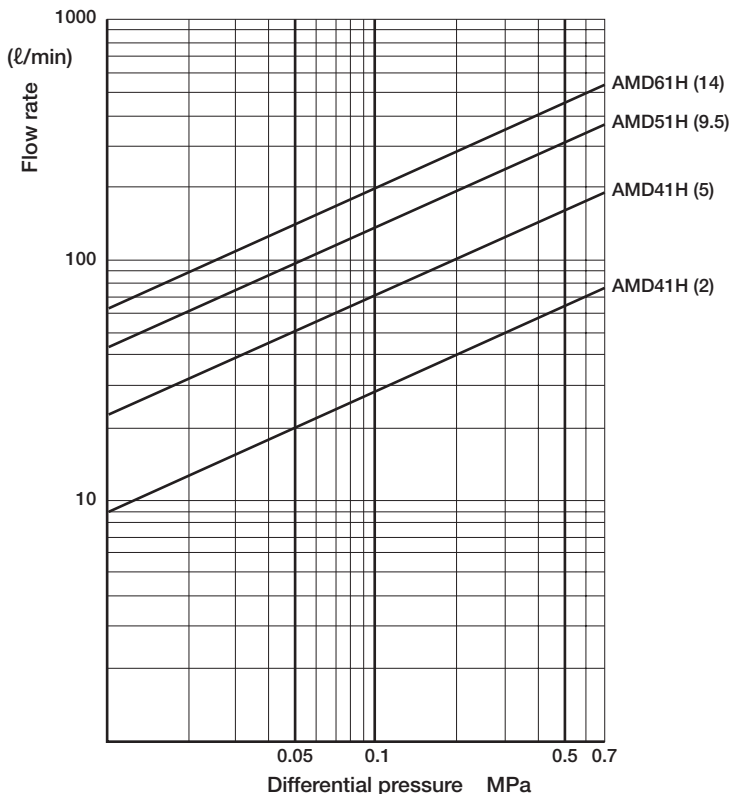

#### AMD31M/AMD51M

● Flow rate characteristics (water)  
Differential pressure vs. flow rate, Cv value in ( )

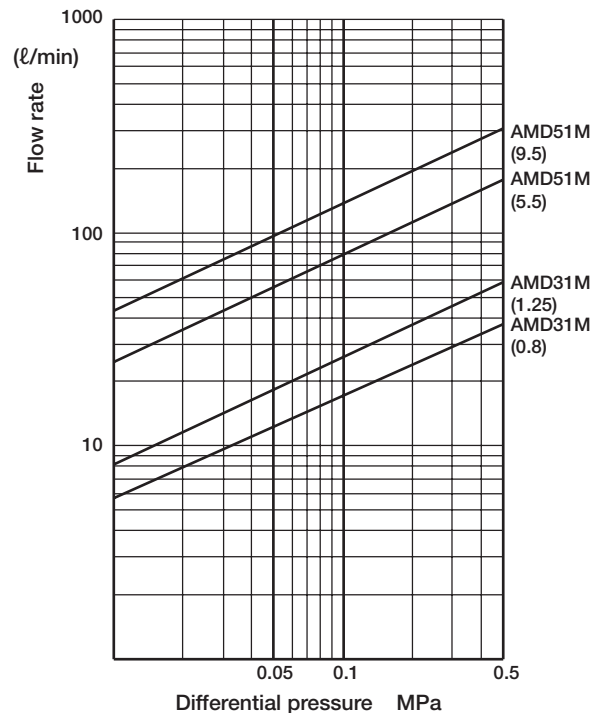

AMD23R
AMD33R
AMD0
AMDZ
AMD02
AMD32
AMD42
AMD52
AMD1H
AMD1M
AMG23R
AMG33R
AMG00
AMG20
AMG02
GAMD23R
GAMD02A
GAMD22
High pressure specifications
AMD
Flow characteristics
MMD02
MMD0H
MMD0M
GMMD02
MMD00
TMD02
FMD00
MNV
AMS
AMDS
Fine regulator
KML
Others
Related

# Fine System devices

## Flow characteristics

### AMD0□2 to AMD5□2

- With flow rate adjustment (water)  
No. of rotations vs. flow rate

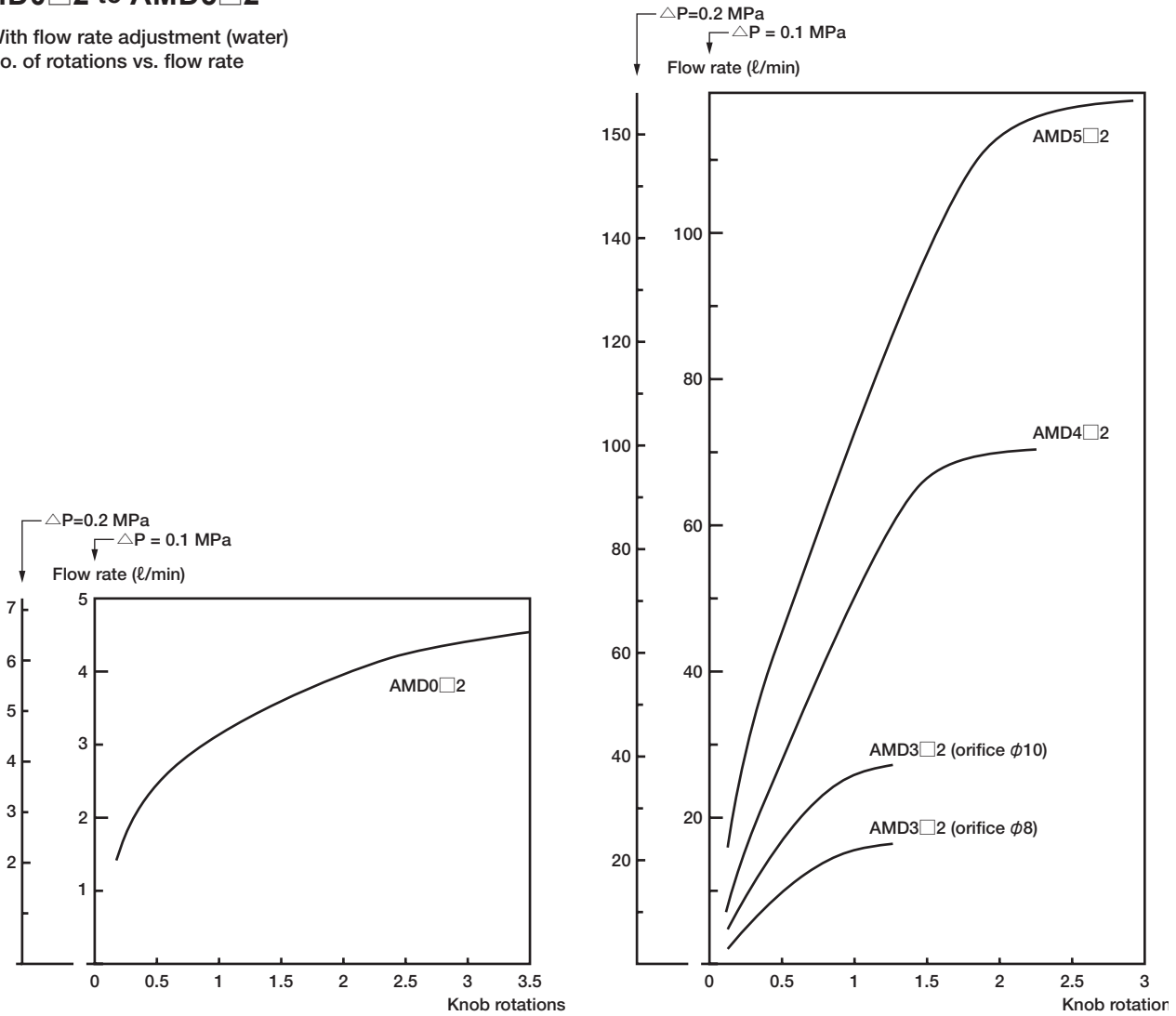

Note 1: Open the adjusting knob at least 1/4 turn from the completely closed state. If used below this level, vibration or flow rate fluctuation may occur depending on the working conditions.

- With bypass (water)  
No. of rotations vs. flow rate

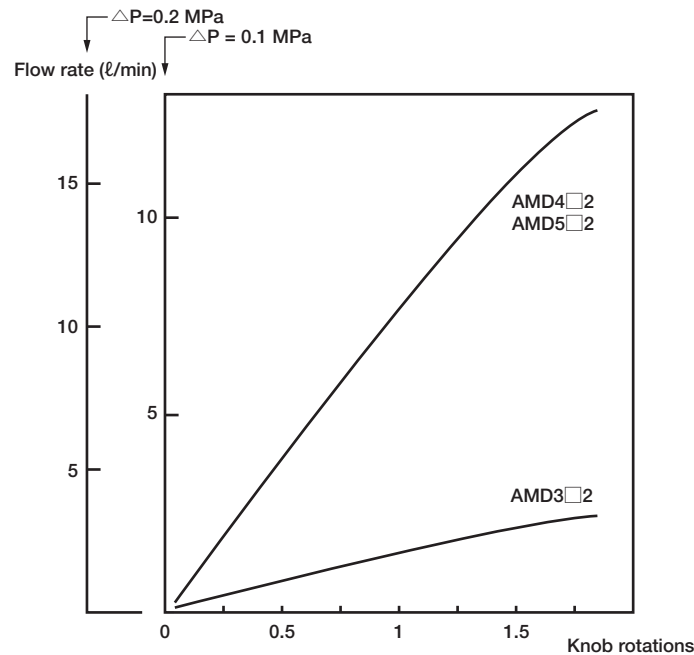

### Flow characteristics

#### AMDZ to AMD5□

- Flow rate characteristics (water)  
Differential pressure vs. flow rate, Cv value in ( ) (ℓ/min)

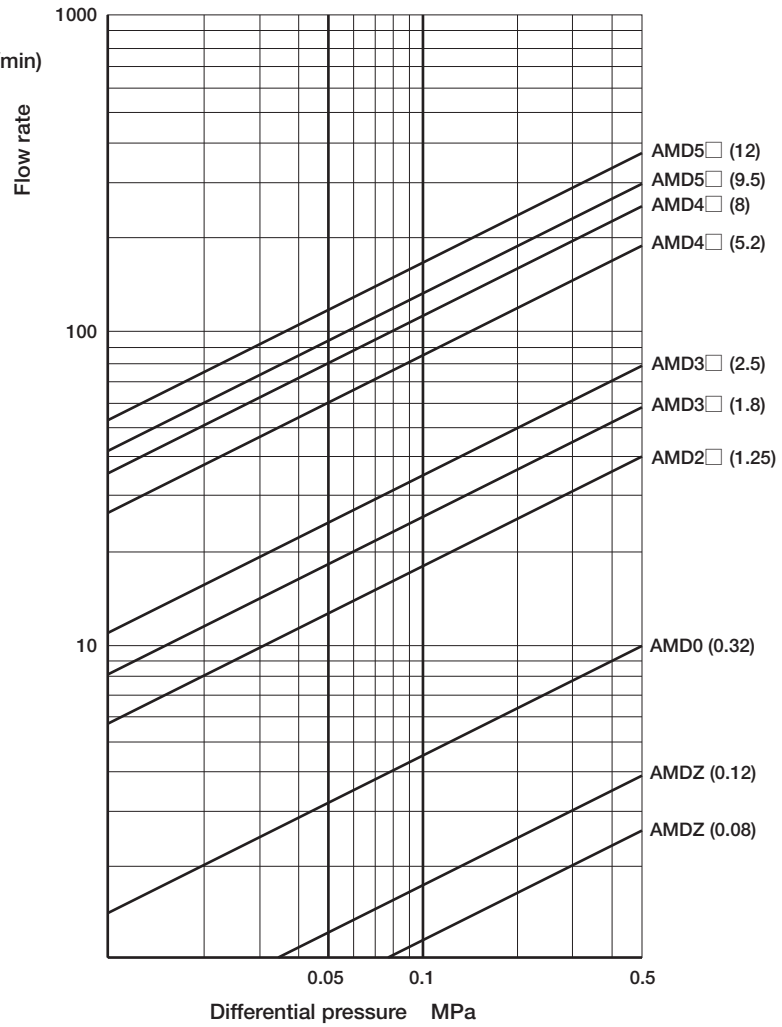

- Bypass section Flow rate characteristics (water)  
Differential pressure vs. flow rate, Cv value in ( ) (ℓ/min)

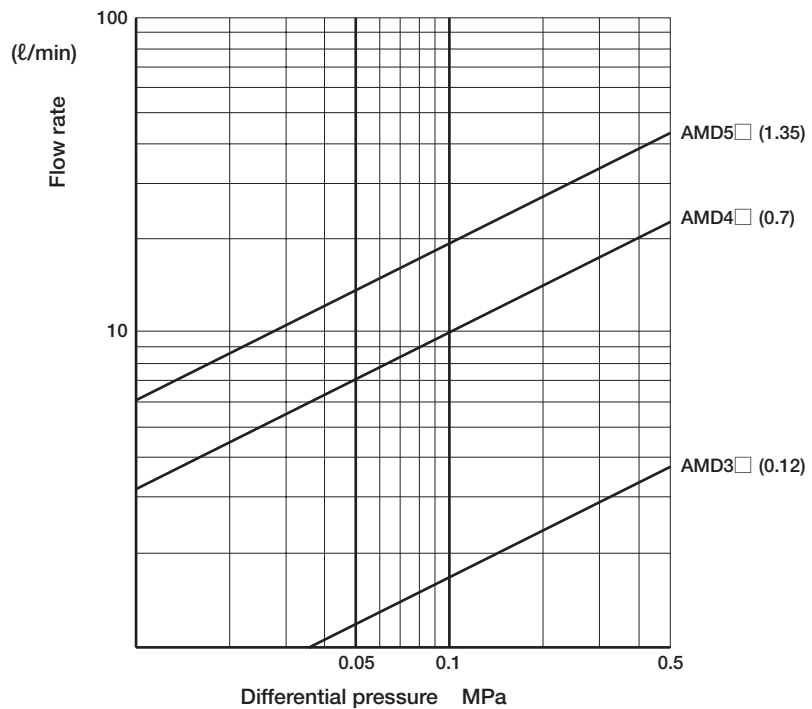

AMDZ3R
AMD3R
AMD0
AMDZ
AMD0*2
AMD3*2
AMD4*2
AMD5*2
AMD*1H
AMD*1M
AMG203R
AMG303R
AMG00
AMG*02
GAMDZ3R
GAMD*3R
GAMD*2A
GAMD*+2
High pressure specifications
AMD
Flow characteristics
MMD*02
MMD*0H
MMD*0M
GMMMD*02
MMD*+0
TMD*02
FMD00
MNV
AMS
AMDS
Fine regulator
KML
Others
Related

# Fine System devices

## Flow characteristics

### AMDZ to AMD5

- With flow rate adjustment (water)  
No. of rotations vs. flow rate

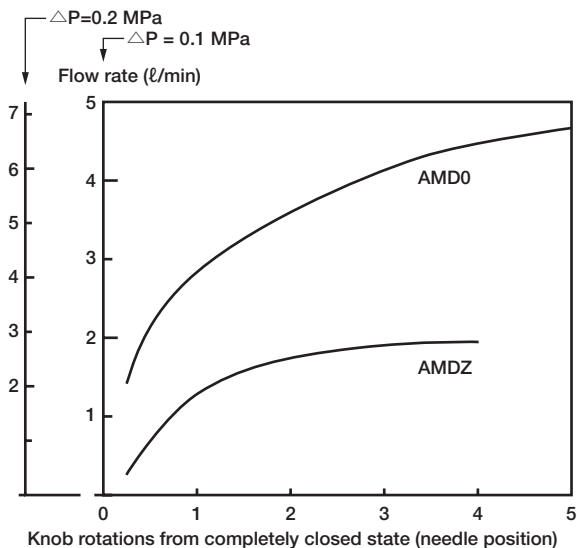

Note 1: Open the adjusting knob at least 1/4 turn from the completely closed state. If used below this level, vibration or flow rate fluctuation may occur depending on the working conditions.

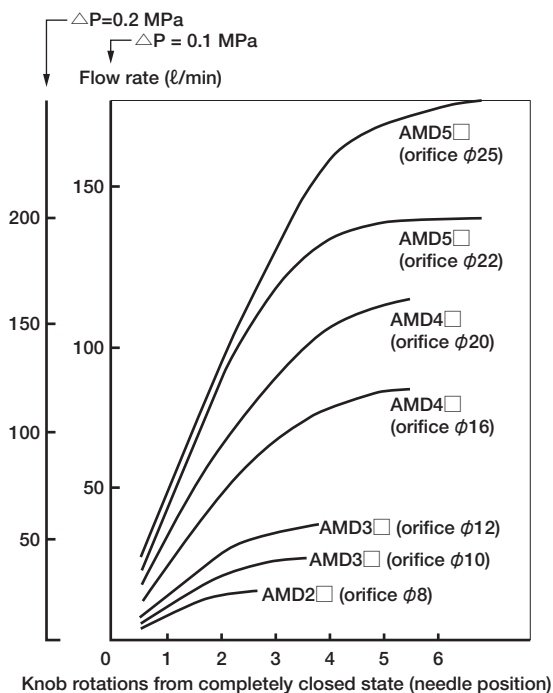

Note 1: Open the adjusting knob at least 3/8 turn from the completely closed state. If used below this level, vibration or flow rate fluctuation may occur depending on the working conditions.

- With bypass (water)  
No. of rotations vs. flow rate

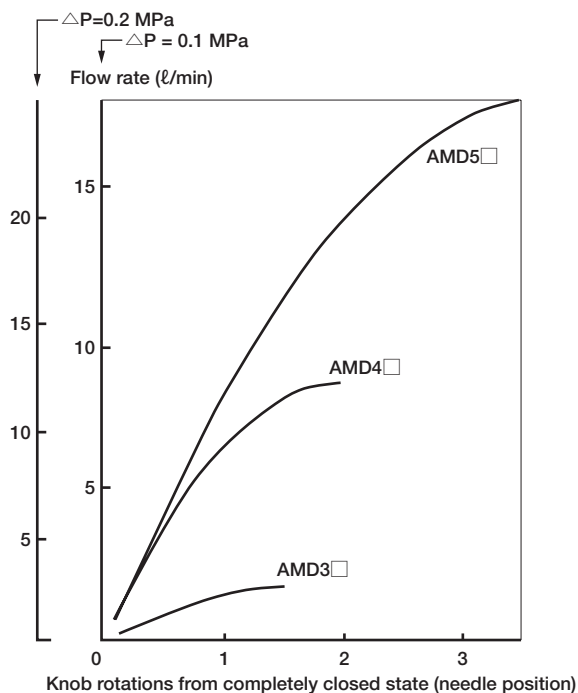

### Flow characteristics

#### GAMD0□2A

- Flow rate adjustment (water)  
No. of rotations vs. flow rate

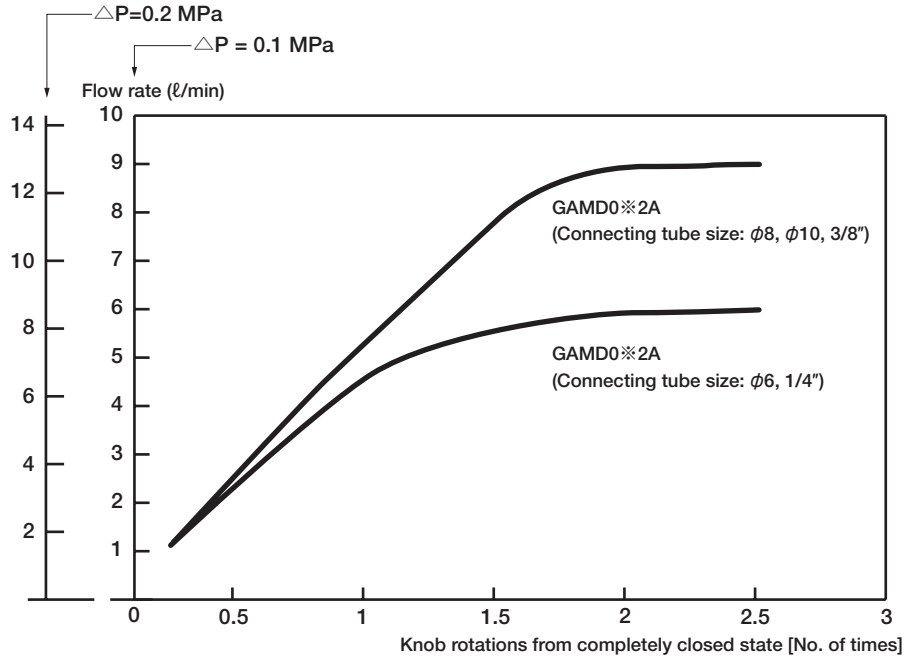

Note 1: Flow characteristics for A port fitting size of φ10.

Note 2: Flow characteristics when flowing from the A port to the B port.

Note 3: Open the adjusting knob at least 1/4 turn from the completely closed state.  
If used below this level, vibration or flow rate fluctuation may occur depending on the working conditions.

AMD*3R
AMD*3R
AMD0
AMD0*2
AMD3*2
AMD4*2
AMD5*2
AMD*1H
AMD*1M
AMG20R
AMG30R
AMG00
AMG*02
GAMD*3R
GAMD0*2A
GAMD*+2
High pressure specifications
AMD
Flow characteristics
MMD*02
MMD*0H
MMD*0M
GMMD*02
MMD*+0
TMD*02
FMD00
MMV
AMS
AMDS
Fine regulator
KML
Others
Related